

The **COLLINS WORKALL®** tractor is ideal for challenging jobs, for example:

- Eco-friendly forestry, farming
- Small scale forestry operations
- Landowners who don't want to own and maintain multiple machines
- Rough terrain mowing
- Forestry firefighting and municipal utility work
- Job limited only by owner's creativity!

The **COLLINS WORKALL®** tractor is Engineered from the Ground Up!

- Horsepower - continuous 73 - Diesel or Gas
- Tire size: 12.4 x 24 agricultural tread
- Transmission - hydrostatic
- Tanks capacities: 23 U.S. gallons
- Steering: hydraulic - two cylinders
- Weight: +/- 9000 lbs. with flat stake body and front blade

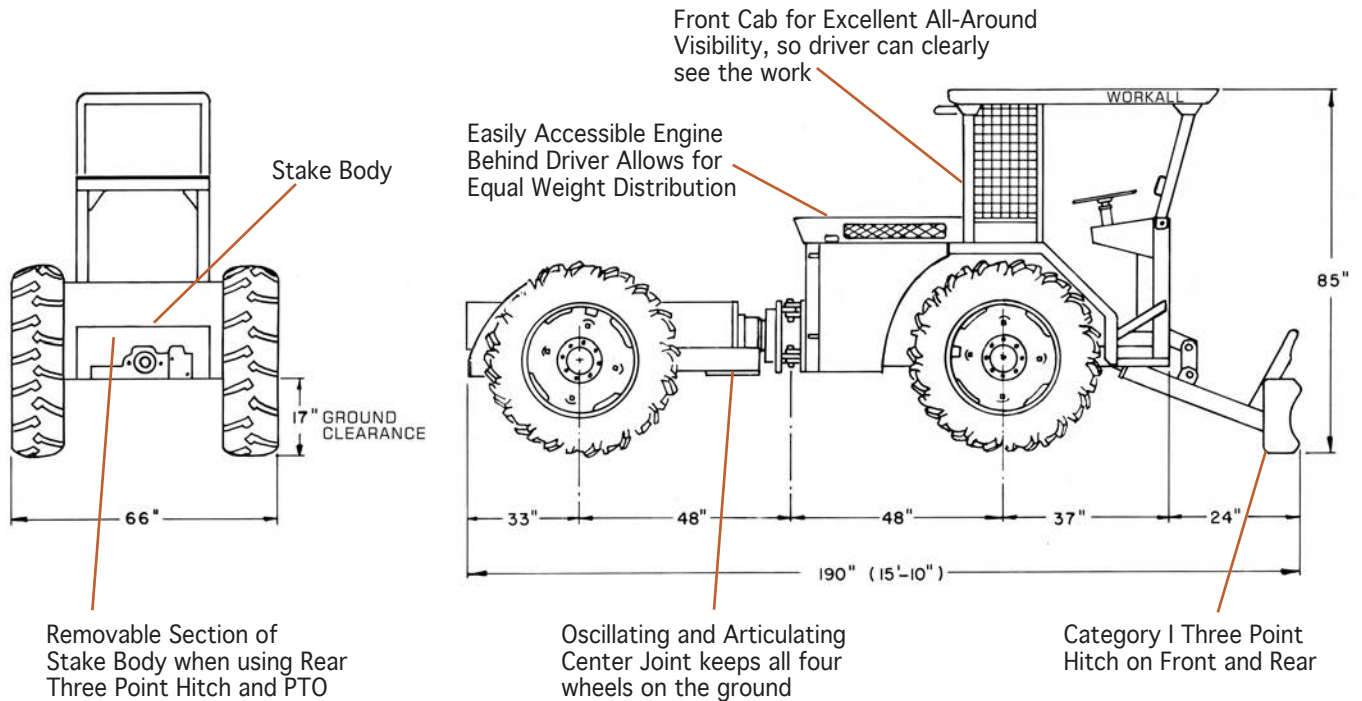

STANDARD FEATURES

- Foot controlled hydrostatic four wheel drive. Four individual wheel motors
- Infinitely variable speed. 0-13 mph
- Center articulating and oscillating
- Full instrument panel
- Lights front and rear
- Enclosed cab with ROPS/FOPS/OPS
- Live PTO - 40 HP - front and rear (not both at same time)
- Auxiliary Disconnects (2) on front and rear
- Flat Body with slots for stakes - removable section when using three point hitch

OPTIONS

- Diesel Engine 73 HP
- Gas Engine 73 HP
- Dump Cylinder and connections
- Quick Attach Plate - Category I (Skid Steer equipment up to HP rating of Mfg)
- Heater, Air Conditioner
- Back-up Camera



COLLINS WORKALL®
Nelson Tractor LLC Maury Collins



521 Old Stoddard Road, Nelson, NH 03457 Tel. 603-313-3321 Email: collinswmaury1936@gmail.com